

# EC1551 Series.

Platic Impeller / Explosion Proof.

Size : 172 x 150 x 51  
Unit : mm

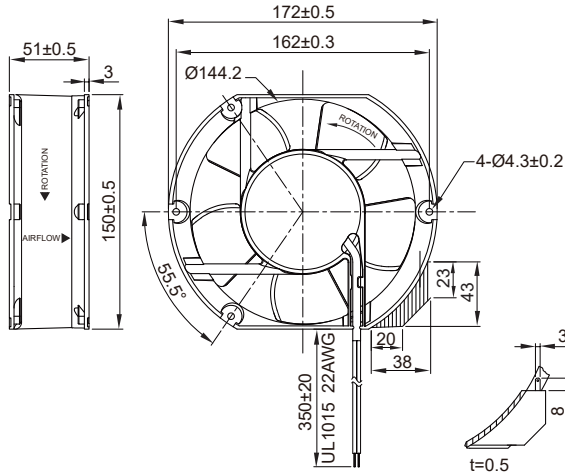

(Axial Fan)

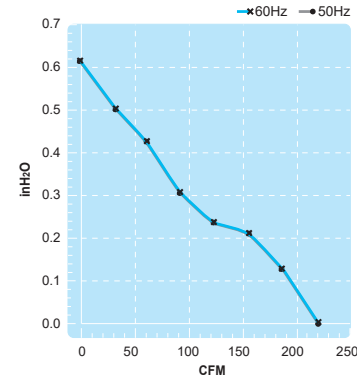

Electronically-Protected

Terminal or Lead Wire Type



Spec.	Rated Voltage	Frequency	Input Power	Rated Current	Locked Current	Speed	Maximum Air Flow	Maximum Air Flow	Maximum Pressure	Maximum Pressure	Noise	Weight
Model	V	Hz	W	A	A	RPM	m <sup>3</sup> /min.	CFM	mmH <sub>2</sub> O	InchH <sub>2</sub> O	dB	kg
EC1551-11M1D4Aex	115	50/60	15	0.23	0.25	3000	6.2	220	15.7	0.62	57	0.7
EC1551-23M1D4Aex	230	50/60	15	0.14	0.47	3000	6.2	220	15.7	0.62	57	0.7